

# TECHNICAL DATA SHEET

## PRIMUS Bio→Pharma® Small Size Sterilizers

*These sterilizers are for customers who require a high quality steam pressure sterilizer whose products, operations and manufacturing facilities are regulated by the FDA. PRIMUS Sterilizers, designed and manufactured in the USA according to Quality Management Systems, are in compliance with ISO 9001:2008, ISO 13485 and FDA's Good Manufacturing Practice (GMP) for Medical Devices: General Regulation (21CFR Part 820). Small size sterilizers are one of 21 standard sizes manufactured by PRIMUS, or we can custom manufacture a sterilizer to meet your specifications.*



26"x 26"x39" shown with PSS7 Control

### STERILIZER DESIGN

PRIMUS Bio→Pharma® sterilizers are designed for a wide range of sterilizing applications suitable for the laboratory or pharmaceutical industry. Quality materials and workmanship have been incorporated into the chamber, piping and controls to provide a pharmaceutical sterilizer that exceeds industry standards. Bio→Pharma® sterilizers are designed for fully automatic, computer-controlled, operations with vacuum or gravity displacement cycles for terminal sterilization to in-process sterilization of packaging components to production equipment sterilization. Bio→Pharma® sterilizers are the choice when versatility, rigorous tolerances and validatable results are essential. The sterilizer is designed, manufactured and tested at the PRIMUS Bio→Pharma® factory in Great Bend, Kansas USA.

PRIMUS vertically operating doors operate with minimal hand pressure. The Pri-Matic® control PLC provided hands-free door operation.

The PRIMUS vertically sliding door design is efficient, reliable and inherently safe.

### STERILIZER CYCLES

Standard cycles can be configured through the use of the cycle parameters to process hard goods, wrapped goods or liquid type products. Configuration of the cycle parameters (i.e., number of PRE or POST-PULSES, EXHAUST & DRY, etc.) is unique to each cycle and depends upon the specific product being sterilized. Standard cycles can be designed for steam sterilization of various types of dry goods or liquid products. Dry good products such as filter housings and cartridges, textiles, rubber stoppers or sterilizable plastic packaging may require preconditioning for air removal from the top of flasks. A slow exhaust is used for liquid products with Jacket Off and Flow Cooling selected after exposure to reduce boil-over.

PRIMUS Pri-Matic® controls offer the user access to thirteen password-protected cycles. Cycle parameters for each cycle are baselined, validated and "locked" by validation personnel. Cycle can be custom named to assist and confirm operator selection of correct cycle.



**PRIMUS**

Sterilizer Company, LLC • 8719 South 135<sup>th</sup> Street Ste 300 • Omaha, NE 68138  
Phone (402) 344-4200 • Fax (402) 344-4242 • [info@primus-sterilizer.com](mailto:info@primus-sterilizer.com) • [www.primus-sterilizer.com](http://www.primus-sterilizer.com)



## PURCHASING SPECIFICATION DATA SHEET

### GENERAL *(Options italicized)*

All models shall include Vacuum, Gravity and Liquids cycles.

### VESSEL MATERIAL AND CONSTRUCTION

The sterilizer features a SA240 TY316L stainless steel (SS) rectangular, horizontal, completely jacketed chamber, with fully radiused longitudinal corners and mirror polished to provide the most hygienic, long lasting appearance and durability available. The chamber has a full-length baffle and drain positioned in the chamber to maximize steam distribution and cross flow within the chamber.

B	26"x26"x39"
C	26"x26"x49"
D	26"x26"x67"

The jacket is constructed of SA240 TY316L SS and is designed to achieve uniform distribution of steam. The jacket enables the stabilization of temperature around the chamber thereby reducing the time required to bring the chamber up to sterilization temperatures, providing superior temperature distribution, and preventing the formation of condensation on the chamber walls.

### DESIGN and MANUFACTURING APPROVALS

The vessel will be designed and constructed to ASME code Section VIII Division I and pressure rated for 45 PSIG and full vacuum. ASME Code Stamp and U-1 form will bear the name of the specified US manufacturer.

The sterilizer will be manufactured according to Quality Management Systems which are in compliance with ISO 9001:2008, ISO 13485:2003, CMDCAS and will be UL listed and in conformance with CSA requirements.

### DOOR CONSTRUCTION

An inherently safe design, counterbalanced vertically operating door will operate with minimal hand pressure and will operate within the overall dimensions of the sterilizer frame. In the open position, the insulated door shall be secured behind a panel preventing the operator from contact with hot surfaces. An interlock will prevent cycle start unless door is closed and secured.

### GENERAL CONSTRUCTION

The vessel will be insulated with 1" semi-rigid high temperature fiberglass board/blanket insulation overlaid with formed aluminum paneling and mounted in a structural steel frame. The frame will be enamel coated and fitted with adjustable legs on self-centering floor pads.

The fascia and side panels will be 16-gauge, type 304 stainless-steel, removable for easy service access.

### EQUIPMENT WARRANTY

Sterilizer pressure vessels manufactured by PRIMUS are warranted against defects in workmanship and materials under normal use and operation for fifteen years where the sterilizer is continually maintained under PRIMUS service contract.

### SERVICE and EQUIPMENT ACCESS

Standard service access, when facing the unit, will be from left side and top. Wiring will be laid side-by-side and mechanically secured flat against the metal insulation cover. All wiring will be clearly labeled and readily visible for visual tracing. All sterilant piping in the product contact circuit is composed of stainless steel with high quality tri-clamp, flanged, sanitary fittings. Sanitary pipe clamps are located anywhere cGMP Procedures require frequent maintenance access to process piping to allow ease of routine cleaning and maintenance. Wiring and piping components will be non-proprietary, industry grade, available through Authorized Service Agencies, local supply house, or direct from PRIMUS.

### STEAM SOURCE

Steam will be from an in-house steam source in the quantity and quality specified. *Optional electric steam boiler, clean steam boiler, or steam-to-steam generator may be specified. Contact PRIMUS for additional information.*

### CONTROLS

Three control systems are available. Pri-Matic® Control System PSS7 uses the Allen-Bradley ControlLogix PLC with an Allen-Bradley Panel View Plus 1000 Operator Interface Terminal (OIT). Pri-Matic® Control System PSS9 uses the Allen-Bradley MicroLogix 1400 PLC Control with an Allen-Bradley Panel View Plus 700. The PSS8 Trinity Control is a microcomputer system with a touch screen. All control software packages provide automatic cycle operation. The control systems hardware is mounted within a separate control cabinet. The systems feature Pulse Width Modulation (PWM) temperature control. All software meets or exceeds industry standards, is fully documented, validated and maintained under strict configuration control.

### CONTROL PANELS



**PSS7 Pri-Matic®  
ControlLogix  
Panel with Printer**



**PSS9 Pri-Matic®  
MicroLogix**



**PSS8 Trinity  
Panel with  
Printer**



**SINGLE DOOR**

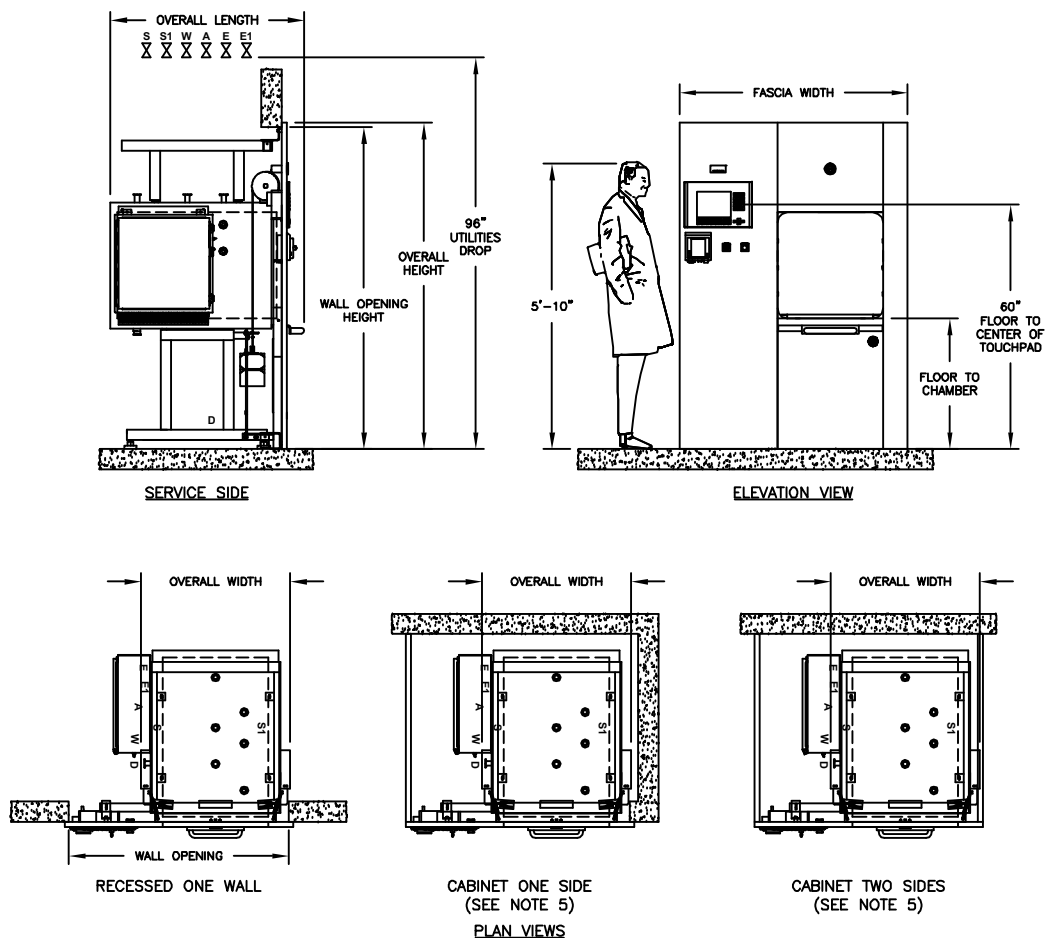

**VOLUME/DIMENSIONS CHART**

\*Refer to General Arrangement (GA) drawings for details and final connection point to utility services (S-Pure Steam, S1-Building Steam, W-Water, D-Drain, E-Electrical, A-Air).

MODEL	B	C	D
<b>Chamber Size (w x h x l) inches/millimeters</b>	<b>26 X 26 X 39 660.4 X 660.4 X 990.6</b>	<b>26 X 26 X 49 660.4 X 660.4 X 1244.6</b>	<b>26 X 26 X 67 660.4 X 660.4 X 1701.8</b>
<b>Chamber Capacity</b>	<b>15.3 cu. ft / .43 cu. m.</b>	<b>19.2 cu. ft / .54 cu. m.</b>	<b>26.2 cu. ft. / .74 cu. m</b>
Overall Width	42.00 / 1066.8	42.00 / 1066.8	42.00 / 1066.8
Overall Height <sup>1</sup>	80.00 / 2032.0	80.00 / 2032.00	80.00 / 2032.0
Overall Length (SD) <sup>2,3</sup>	47.56 / 1208.0	57.56 / 1462.1	75.50 / 1917.7
Wall Opening Width <sup>4</sup>	54.00 / 1372.0	54.00 / 1372.0	54.00 / 1372.0
Wall Opening Height	79.00 / 2006.6	79.00 / 2006.6	79.00 / 2006.6
Wall Opening Length	46.00 / 1168.4	54.00 / 1371.6	72.00 / 1828.8
Fascia Width <sup>1</sup>	56.0 / 1422.0	56.0 / 1422.0	56.0 / 1422.0
Floor to Chamber	32.00 / 812.8	32.00 / 812.8	32.00 / 812.8

1. Fascia extends 1" beyond wall opening on each side overlapping the wall and sealing the opening.
2. Allow minimum 2" clearance at rear of recessed unit only. Cabinet side models have rear clearance built in.
3. Handle projects from the face of the fascia to the outer radius of the handle. Models B, C, & D the handle projects 4.25".
4. Contact PRIMUS for alternative wall opening.
5. Standard Left Side Service/equipment access shown. Optional right side access is available.



**DOUBLE DOOR**

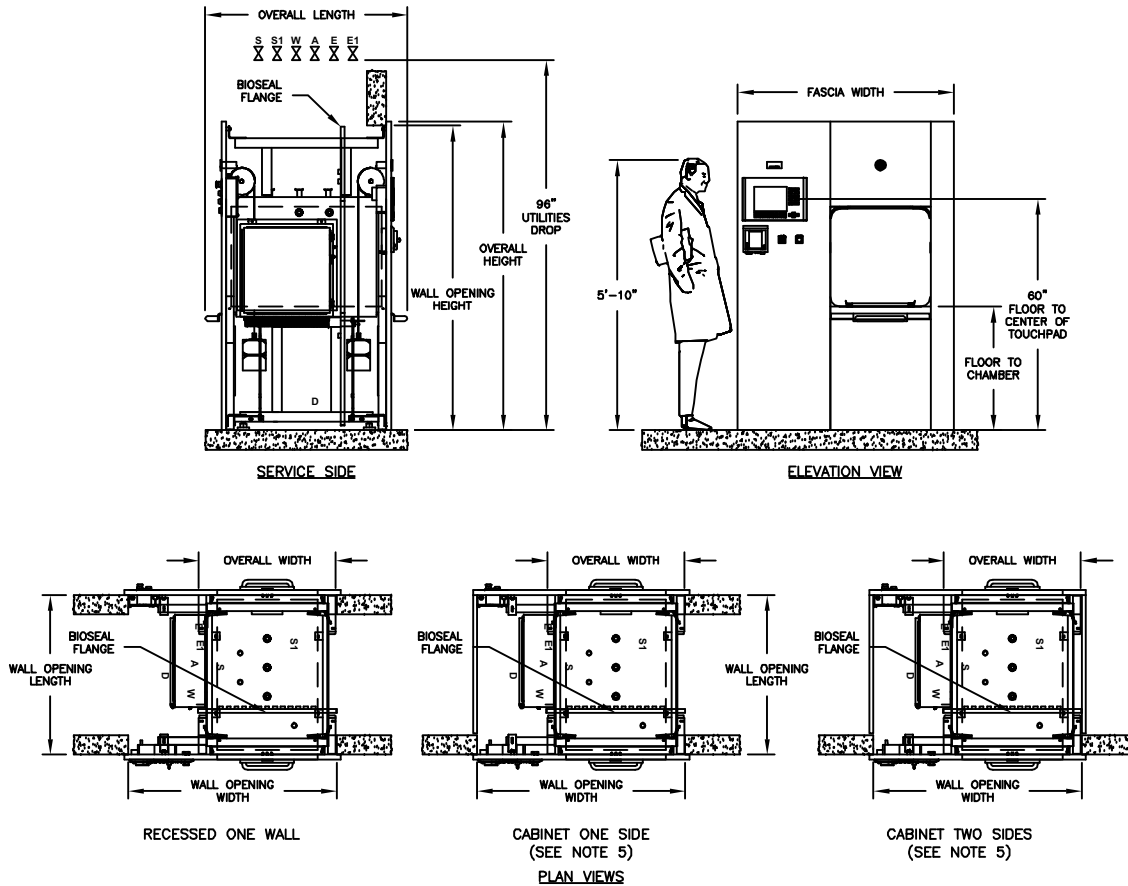

**VOLUME/DIMENSIONS CHART**

\*Refer to General Arrangement (GA) drawings for details and final connection point to utility services (S-Pure Steam, S1-Building Steam, W-Water, D-Drain, E-Electrical, A-Air).

MODEL	B	C	D
<b>Chamber Size (w x h x l) inches/millimeters</b>	<b>26 X 26 X 39 660.4 X 660.4 X 990.6</b>	<b>26 X 26 X 49 660.4 X 660.4 X 1244.6</b>	<b>26 X 26 X 67 660.4 X 660.4 X 1701.8</b>
<b>Chamber Capacity</b>	<b>15.3 cu. ft. / .43 cu. m.</b>	<b>19.2 cu. ft. / .54 cu. m.</b>	<b>26.2 cu. ft. / .74 cu. m.</b>
Overall Width	35.50 / 901.7	35.50 / 901.7	35.50 / 901.7
Overall Height <sup>1</sup>	80.00 / 2032.0	80.00 / 2032.0	80.00 / 2032.0
Overall Length (DD) <sup>3</sup>	52.44 / 1331.9	62.44 / 1585.98	80.44 / 2043.18
Wall Opening Width <sup>4</sup>	54.0 / 1372.0	54.0 / 1372.0	54.0 / 1372.0
Wall Opening Height	79.00 / 2006.6	79.00 / 2006.6	79.00 / 2006.6
Wall Opening Length	41.44 / 1052.6	51.44 / 1306.6	69.44 / 1763.8
Fascia Width <sup>1</sup>	56.0 / 1422.0	56.0 / 1422.0	56.0 / 1422.0
Floor to Chamber	32.00 / 812.8	32.00 / 812.8	32.00 / 812.8

1. Fascia extends 1" beyond wall opening on each side overlapping the wall and sealing the opening.
2. Handle projects from the face of the fascia to the outer radius of the handle. Models B, C, & D the handle projects 4.25".
3. Contact PRIMUS for alternative wall opening.
4. Standard Left Side Service/equipment access shown. Optional right side access is available.

## ARCHITECTURAL NOTES:

1. Allow sufficient space for traps, shut-off's, filters and other utility supply components.
2. Utility (service disconnects) shall be provided and installed "By Others".
3. Building or structure modifications to accommodate the sterilizer, as well as, sterilizer shoring, rigging, cribbing and/or crane requirements into the facility shall be provided "By Others".
4. Provide maximum mechanical and service access space, a minimum of 24", additional space required when boiler specified. See General Arrangement drawing for placement of ancillary equipment and service access.
5. Some options affect utility services and overall dimensions.
6. Water Quality - Refer to page 8.
7. The Manufacturer's Equipment Warranty does not cover failure due to improper utility provisions.
8. Drawings not to scale.
9. Wall thickness must be provided on single and double door models recessed through 1 wall, with cabinet sides.
10. Floor under sterilizer must be water tight and sloped to the drain.

## UTILITY SERVICES

Provide utility services within 6'-0" of final connection to sterilizer. Optimum sterilizer performance requires the specified utilities.

MODEL	STEAM (S) Pure Steam Supply . Pipe Size: 1" Sanitary		STEAM (S1) Building Steam Supply . Pipe Size: 3/4" NPT . Quality: Condensate free 97% to 100% saturated vapor (suitably trapped to ensure dry steam and filtered to remove particulates) . Pressure: 50-80 PSIG Dynamic  <b>Note:</b> 1.) Steam-to-steam generator requires minimum pressure 65 PSIG house steam		WATER (W) Cold Water Supply . Pipe Size: 3/4" NPT . Temperature: < 70° F . Pressure: 50-70 PSIG Dynamic		DRAIN (D) Building Drain System Minimum 2"  . Location: Locate floor sink directly under sterilizer  <b>Note:</b> 1.) Exhaust discharge is cooled to < 140°F 2.) 12" x 12" x 8" floor sink is recommended by PRIMUS		Air (A) Instrument Air . Connection: See Below . Quality: Dry and oil free . Pressure: 60-80 PSI Dynamic		ELECTRICAL (E) Building Power Supply . Volts: 110 . Phase: Single . Amps: 10  <b>Note:</b> Additional circuits required for ancillary and optimal equipment i.e., vacuum pump, boost pump, boiler, etc.	
	NPT	LBS/HR (KG/HR)	NPT	LBS/HR (KG/HR)	NPT	GPM (Liter)	NPT (Discharge Pipe Size)	NPT	NPT	NPT		
B	1"	90 (40.82)	3/4"	100.0 (45.36)	3/4"	8 (30)	3/4"	1/4"				
C	1"	120.6 (54.70)	3/4"	134.0 (60.78)	3/4"	14 (53)	1"	1/4"				
D	1"	183.6 (83.28)	3/4"	204.0 (92.53)	3/4"	14 (53)	1"	1/4"				

## HVAC DATA Heat loss, at ambient of 70° F.

	MODEL	KBTU'S/HR
<b>SINGLE DOOR:</b> Through one wall, at fascia	B	4.1
	C	4.1
	D	4.1
<b>SINGLE DOOR:</b> Through one wall, service area	B	5.7
	C	7.1
	D	9.7
<b>SINGLE DOOR:</b> Free standing, cabinet total	B	9.8
	C	11.2
	D	13.8

	MODEL	KBTU'S/HR
<b>DOUBLE DOOR:</b> Through one wall, at fascia	B	4.1
	C	4.1
	D	4.1
<b>DOUBLE DOOR:</b> Through one wall, service area	B	7.8
	C	9.7
	D	11.5
<b>DOUBLE DOOR:</b> Through two walls, at each fascia	B	4.1
	C	4.1
	D	4.1
<b>DOUBLE DOOR:</b> Through two walls, service area	B	3.7
	C	5.6
	D	7.4

## ELECTRIC BOILERS

BEBC Electric Heated Boiler - Stainless steel construction for clean steam generation. Includes stainless steel feedwater boost pump.

**NOTE:** Stainless Steel Boilers shall be operated using only deionized water, having a maximum conductance of 1 microSeimen per cm (1 $\mu$ S/cm) [minimum specific resistivity of 1 megohm per cm (1MW/cm)].

MODEL		B	C	D
Chamber Size (w x h x l) inches/millimeters		26 x 26 x 39 660.4 x 660.4 x 990.6	26 x 26 x 49 660.4 x 660.4 x 1244.6	26 x 26 x 67 660.4 x 660.4 x 1701.8
Boiler Size	kW/Hr.	36.0	48.0	72.0
Boiler Steam Output	lbs./Hr	108.0	145.0	217.0
Integral	Model	EBC1-B <sup>1</sup>	N/A	N/A
Stand Alone	Model	EBC-B	EBC-C	EBC-D
V.A.C. 208, 3 Ph	Amperes	100	134	200
V.A.C.240, 3 Ph	Amperes	87	116	174
V.A.C. 480, 3 Ph	Amperes	44	58	87
V.A.C. 110, 60 Hz <sup>1</sup>	Amperes	10	10	10

1. Controls Current  
N/A - Not Available

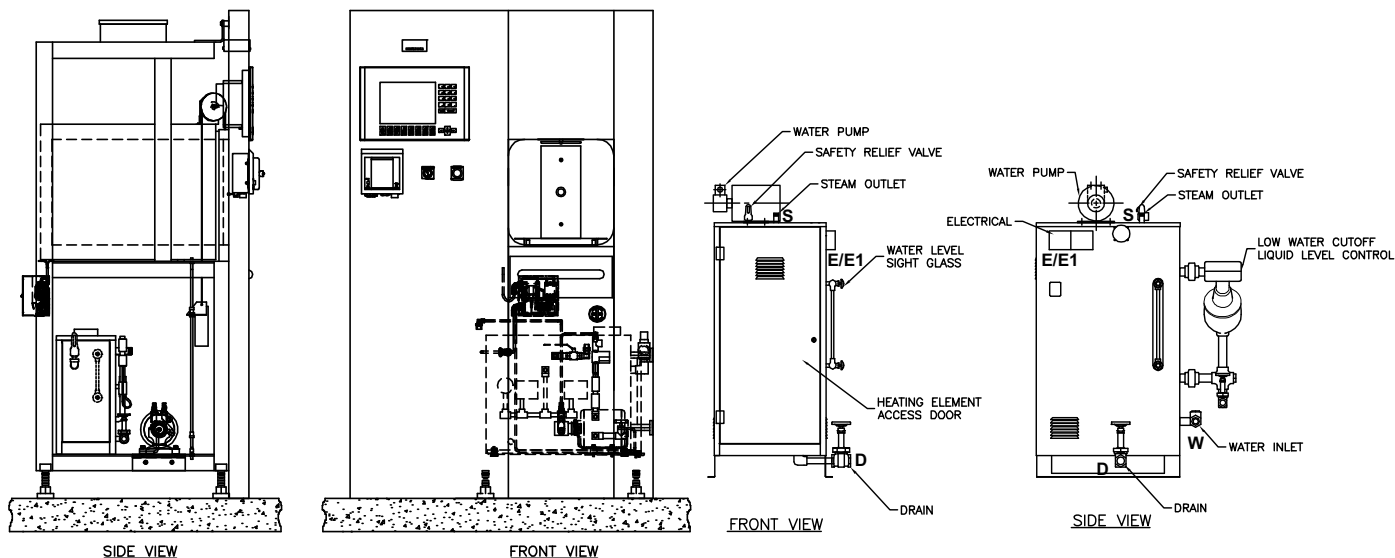



## STEAM TO STEAM GENERATOR (SCS1 & SCS2)

Steam to Steam Generator used to generate either clean or pure steam. The preferred method of generating Clean or Pure steam, when house steam is available to drive the generator. Converts to steam, whatever quality water is delivered.

BSCS1 Pure Steam - stainless steel steam to steam generator with sanitary fittings, double tube sheet construction. Generated from WFI quality depyronated water. The water source to the Pure Steam Generator is either house generated or "By Others".

BSCS2 Clean Steam - stainless steel steam to steam generator with threaded fittings, threaded connections and single tube construction. Generated from distilled or reverse osmosis water. Clean Steam sterilizers normally include stainless steel piping for all wetted surfaces in the product loop.

**NOTE:** Refer to Page 8 for information on Water Quality.  
 Refer to the boiler/steam to steam generator maintenance manual provided with the sterilizer prior to using any boiler treatment chemicals.  
 Contact PRIMUS for further recommendations.

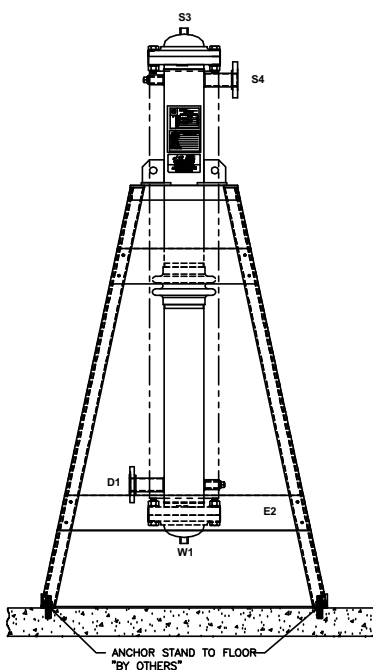
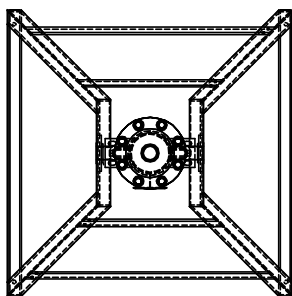

Use the following pages to custom design your sterilizer by checking the boxes of the configuration and options required for your project. Transfer all items checked to the Technical Worksheet (Pages 15 & 16) and fax to PRIMUS Sales Department or to your local Sales Representative for a quotation. If you do not find an option or size listed to meet your requirements, please contact our Project Manager for additional information and assistance with a custom design.

### Model Number Notation

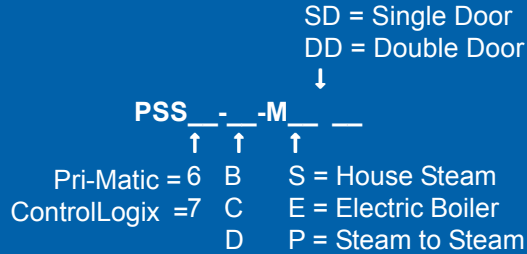

### Three models are offered:

- B - 26" x 26" x 39"
- C - 26" x 26" x 49"
- D - 26" x 26" x 67"

A detailed formatted specification, suitable for inclusion in formal contract documents, is available on request.

**Note:** Use the above format to determine PRIMUS Model number and insert below and on Page 15, Technical Data Worksheet.

PRIMUS Bio→Pharma® Steam Pressure Sterilizer, Model Number PSS\_\_\_\_\_.

## SELECT CONFIGURATION

#### Door

- BDA - Single Door
- BDB - Double Door

#### Cabinet

- BCD - Panels Both sides
- BCCL - Left Side Panel
- BCCR - Right Side Panel

#### Recessed

- BCA - One wall
- BCB - Two walls

#### Service and Equipment Access

- Left Side (Standard)
- Right Side

#### Steam Source

- House Supply
- Clean Steam<sup>2</sup>
  - BEBC1 - 208/3 phase<sup>3</sup>
  - BEBC2 - 240/3 phase<sup>3</sup>
  - BEBC3 - 480/3 phase<sup>3</sup>
  - Other \_\_\_\_\_
  - BEB0<sup>5</sup> - Auto Blowdown
- Steam to Steam<sup>2</sup>
  - BSCS1 - Pure Steam Dbl Tube
  - BSCS2 - Clean Steam Sgl Tube
  - BSCS<sup>4</sup> - Clean Steam Sgl Tube Sanitary
  - Other \_\_\_\_\_

1. Electric boilers are Stainless Steel Electric Boilers. If Bio-Seal, Electric Vacuum Pump or Sanitary Piping options are required, contact PRIMUS for final configuration drawing.
2. Contact PRIMUS for overall dimensions and utility connections.
3. All models are stand-alone.
4. GMP Validatable Option Only, sanitary piping required.
5. Low Water Cutoff is standard and the, "automatic reset" feature is disabled with this option. The boiler will need to be manually reset.
6. Water Quality - For best results, feed water supply should be evaluated prior to initial startup to ensure it is of the quality necessary for the application, various external treatment processes (water softener, water conditioning, etc.) may be used. Contact PRIMUS for further recommendations.



## PHARMACEUTICAL CONFIGURATIONS

**Clean Steam Sterilizers P9**

For cell/tissue culture applications. This option provides direct connection to a house-source of clean steam. Includes threaded stainless piping and components to chamber. If clean steam is only steam source, specify option BP9.1 for stainless piping to jacket. For alternate sources to generate clean steam, specify electric clean steam boilers (stainless steel), or when house steam is available, specify steam-to-steam generators. (Stainless steel heat exchanger).

P9	Stainless piping to chamber - threaded
P9.1	Stainless piping to jacket - threaded
EBC	Clean Steam Stainless Electric Boiler (specify voltage)
SCS1*	Pure Steam Double Tube Sheet, Sanitary Connections
SCS2*	Clean Steam Single Tube Sheet with threaded connections
SCS3*	Clean Steam Single Tube, Sanitary Connections

\*Contact PRIMUS for alternate steam generator options.

**Air-over Cooling P11**

Provides a means of rapidly cooling sterilized load. Effective to decrease cycle times with liquid loads. Filtered ambient air displaces steam during exhaust cycle to rapidly cool load and prevent boil-over.

**Clean In Place Piping P15**

CLEAN-In Place (CIP) piping is standard. CIP piping has an interior finish <25 μ Ra.

**Control Cycle on Load Temperature C24**

Use to establish the most beneficial cycle temperature and exhaust rate parameters. Monitors and controls the load temperature. Use to establish best parameters for liquid loads and for loads with complex geometries and a tortuous path for steam penetration.

*Note: See additional Bio-Containment Options*

## CONTROLS AND RELATED OPTIONS

*(Contact PRIMUS for details and performance specifications)*

**PSS7 Control System C7**

PSS7 uses the Allen-Bradley ControlLogix PLC with Ethernet connectivity and PanelView Plus 1000 OIT in place of the SLC500 PLC and standard PanelView. ControlLogix® provides graphical color touch screen capability, real time process graph, active Plumbing & Instrumentation Diagram (P&ID) screens and the ability to standardize control systems throughout a facility. PSS7 offers a total of fifteen (15) cycles with thirteen (13) standard cycles available for product sterilization. Standard cycles are configurable by modifying the cycle parameters for each. Two dedicated cycles are available for performing vacuum leak test and sterilizer filter.

**PSS8 Trinity Control System C8**

PSS8 microcomputer with a selection of twenty-five (25) separate programs for sterilization of wrapped goods, hard-goods, liquids and test cycles. Trinity Controller has a color touch sensitive screen with 30 line x 40 character display mounted on the front fascia with a thermal printer. Help screens for programming and trouble shooting alarm conditions. Cycle data can be printed, captured to a remote personal computer or logged to memory.

**PSS9 Control System C9**

PSS9 uses the Allen-Bradley MicroLogix™ 1400 PLC control and PanelView Plus™ 700 display monitor which provide a touch sensitive screen featuring color active matrix (TFT) 18 bit color graphics display and real time graph. Twenty-seven cycles, with 25 standard cycles available for product sterilization and two dedicated cycles for performing vacuum leak test and sterilizer filter. Help screens for programming and troubleshooting alarms. Messages displayed in complete phrases with no cross-referenced codes required. Cycle data printed, captured to a remote personal computer, or logged to memory. Security Access for Operator, Supervisor, Calibrator, Service and Administrator. Calibration provided through the operator end touch screen.

**Sterilization Based on Accumulated F<sub>0</sub> C2**

When sterilization based on accumulated heat lethality F<sub>0</sub> is selected, exposure length is based on a settable value for the total accumulation of F<sub>0</sub> during the charge and exposure phases. The accumulated F<sub>0</sub> value must be reached before the sterilization phase is completed.

## CONTROLS AND RELATED OPTIONS (CONT'D)

**Supervisory Control and Data Acquisition (SCADA) System C8**

The optional SCADA Interface provides the end user with a structured data format which can be easily interfaced with control room processes.

**Remote Record of Run Data C11**

Supervisory use to capture electronic record of each sterilization cycle. Cycle hard copy and display data is transmitted via RS232 in real time to remote computer, up to 100 feet away, for display and recording. Hard copy records may be printed from the computer. Available on both control systems.

**Sterilize Filter Cycle C13**

Sterilize filter is a stand-alone cycle used to sterilize the 0.2 micron sterile air filter, filter housing and related piping.

**BioSeal Flange V6**

Provides a means of isolating load from the unload ends of the sterilizer. A vapor-proof flange is welded to the vessel on both sides of the flange and around its full circumference. Penetrations through the flange for electrical and piping components are secured with vapor proof fittings. Optional on single door units, standard on double door units. For double-door pass-through Model B requiring BioSeal Flange and a boiler, specify a stand-alone boiler.

**Air Differential/Vermin Seal Extension Panels V7**

Aluminum panels for attachment to, and extending from, the BioSeal Flange to adjacent building surfaces to complete the barrier between either end of the sterilizer.

	V10	Air Differential/Vermin Seal, Sealant, SS
--	-----	---

**BioSeal Fully Welded Box V11**

Provides a fully welded stainless box, welded to the BioSeal flange forming the complete BioSeal. Check proposed installation site. Install into wall opening with end-opposite box BioSeal, first. For double-door pass-through model B requiring a Box BioSeal and a boiler, specify a stand-alone boiler.

**Validation Port, 1 inch V3.1**

Provides chamber penetration to accommodate various monitoring/control probes. Standard on B, C, and D models.

**Seismic Restraints BV8**

Required in areas prone to seismic hazards. Secures sterilizer to building but allows for leveling. Designed to current California Code.

**Authorized Operator Access C32**

Restricts operation of sterilizer to authorized personnel and provides supervisor with PIN number of person running the cycle. Access levels are available for administrator, supervisor and operator level groups.

**Remote Mount Control Panel C10**

Mount control panel in separate housing adjacent to or up to 100 feet away from the sterilizer. Available on both control systems.

**Thermal Printer R7**

Thermal dot-matrix printer with take-up reel and 32 characters per line printing is standard. Second sterilization cycle report available at the end of the run.

## BIO-CONTAINMENT OPTIONS

**Conax Adapter C5**

Provides two (2) 316L SS sanitary chamber penetration, for validation purposes. Conax Adapter provides a compression gland inside the port, through which 1-24 thermocouple leads are fed to the chamber interior.

**Remote Signaling of Sterilizer Status C23**

Control relay connection enabling operation of a remote signaling device for an alarm condition. Alarm conditions many include Door Open, Door Closed and Cycle complete. Signal may be used to activate a buzzer, light or any other On-Off device.

**Compress Air to Gasket P10**

Compressed air is used to seal gasket against door interior during cycles on Bio→Pharma® sterilizers. Prolongs gasket life. Requires compressed air utility service, or option BEAC air-compressor. Optional steam to gasket is available.

## GENERAL OPTIONS

**Electric Vacuum Pump P4**

A water-sealed electric vacuum pump is standard on sanitary sterilizers providing a vacuum, in lieu of the standard water ejector on non-sanitary sterilizers. Pump is side mounted on Models B. Check PRIMUS' General Arrangement drawing to assure the required ancillary equipment space is provided.

**Drain Line Strainer/Valve BP25**

Provides a means to trap and expel debris from the chamber drain line to protect heat exchanger from damage.

## GENERAL OPTIONS (CONT'D)

### Air Compressor EAC

For small size sterilizers, (less than 75 cu. ft.), air compressor mounted on sterilizer frame, for use when house supplied air is required but not available. Not available if Air-Over Option BP11 is specified.

### Automatically Operated Door DF

On small size models, replaces standard manual fingertip door operation with non-electric, hydraulic power operation actuated by mushroom-button switch mounted adjacent to chamber. Double Door Models include control panel pad actuation in lieu of mushroom button.

## UTILITY - STANDARD FEATURES

### Quench Effluent on Demand to Drain P6

Assures effluent exhausted to drain is 140°F or below, provides quench water for exhaust effluent only on demand, to conserve water. Standard on all units.

### Stepping Transformers E1

Reduces line voltage to required 110 VAC for operation of sterilizer controls.

E1A	220 vac to 110 vac
E1B	480 vac to 110 vac
E1C	480/240/240/120, 1 ph, 0.5 KVA

### Uninterruptible Power Supply E2

In the event of electrical power loss and no emergency electrical power to sterilizer, this option provides electrical power to operate control system for up to 30 minutes, to complete the cycle. This option is dedicated power source for the electronic controls only and will not supply any power requirements for heavy power load components (boiler, compressors, etc.)

## UTILITY - STANDARD FEATURES

### PRI-Saver Water Conservation System P24

Decreases water usage up to 97% on steam sterilization cycles. PRI-Saver recirculates water through the reserve tank. This dramatically increases efficiency by reusing water.

## LOADING EQUIPMENT

Standard chamber shelving includes a fixed removable, wire mesh bottom shelf. As an option extendable bottom shelf, is available. Adjustable shelf supports are provided in 4-inch (100mm) increments. Optional additional chamber shelf(ves) may be specified.

Loading cart includes one bottom and one intermediate shelf with four adjustable levels. Additional shelves are available. Cart frames and shelves are 316L stainless steel welded, ground and polished. Shelf surfaces are stainless steel wire mesh. Transfer carriages include swivel casters with swivel locks and 5" wheels with wheel brakes.

L1	Removable Bottom Shelf
L2	Extendable Bottom Shelf
L3	Additional Chamber Shelf
L4	Loading Cart
L5	Additional Cart Shelf
L6	Transfer Carriage

**NOTE:** Loading cart and transfer carriages are recommended for chamber lengths 48 inches or longer.

*Contact PRIMUS for special loading equipment requirements. Existing loading equipment may be able to be retained, contact PRIMUS for more information.*

## SHIPPING DIMENSIONS, CUBAGE & WEIGHTS

Model Sterilizer Size inches/millimeters	B 26" x 26" x 39" 660.4 x 660.4 x 990.6	C 26" x 26" x 49" 660.4 x 660.4 x 1244.6	D 26" x 26" x 67" 660.4 x 660.4 x 1701.8
Overall Dimensions, of Frame	35-1/2 x 79 x 50 901.7 x 2006.6 x 1270	35-1/2 x 79 x 60 901.7 x 2006.6 x 1524	35-1/2 x 79 x 78 901.7 x 2006.6 x 1981.2
Weight, Single Door	1975 lbs/ 896 kg	2600 lbs/ 1179 kg	3000 lbs/ 11361 kg
Weight, Double Door	2871 lbs/ 1302 kg	3598 lbs/ 1632 kg	4179 lbs/ 1896 kg
Crated Weight (Additional)	200 lbs/ 91kg	200 lbs/ 91kg	200 lbs/ 91kg
Crated Dimensions	51 x 90 x 59 1295 x 2286 x 1499	51 x 90 x 68 1295 x 2133.6 x 1727	51 x 90 x 87 1549.4 x 2133.6 x 2210
Crated Cube	157 cu ft/ 4 m <sup>3</sup>	180 cu ft/ 5 m <sup>3</sup>	231 cu ft/ 7 m <sup>3</sup>
Loading Equipment	153 lbs/ 69 kg	175 lbs/ 79 kg	246 lbs/ 112 kg
Boiler	S.D. 250 lbs/ 113.4 kg <sup>1</sup> D.D. 370 lbs/ 167.8 kg <sup>1</sup>	375 lbs/ 170 kg	450 lbs/ 204 kg

1. Integral Boiler
2. Stand Alone

## LOADING EQUIPMENT (cont'd)

### Transfer Carriage and Loading Cart Dimensions<sup>1</sup>

CHAMBER SIZE	CARRIAGE QTY	CART QTY	A	B	C1	C2	D	E	F
B - 26"x26"x39"	1-L6	1-L4	38.25"	32"	53.63"	41.06"	55.00"	21"	35.50"
C - 26"x26"x49"	1-L6	1-L4	48.25"	32"	53.63"	41.06"	65.00"	21"	45.50"
D - 26"x26"x67"	1-L6	1-L4	65.25"	32"	53.63"	41.06"	82.38"	21"	48"

### Transfer Carriage and Loading Cart Dimensions (cont'd)

CHAMBER SIZE	CARRIAGE QTY	CART QTY	G	H1	H2	J <sup>2</sup>	K	L1	L2	L3
B - 26"x26"x39"	1-L6	1-L4	16.50"	19.50"	20.88"	4"	24"	34"	37"	N/A
C - 26"x26"x49"	1-L6	1-L4	16.50"	19.50"	20.88"	4"	24"	44"	47"	N/A
D - 26"x26"x67"	1-L6	1-L4	16.50"	19.50"	20.88"	4"	24"	62.50"	65"	30.50"

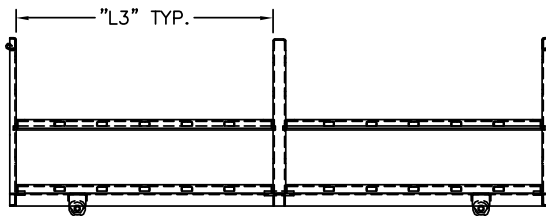

SIDE VIEW (60" CHAMBER OR LONGER)

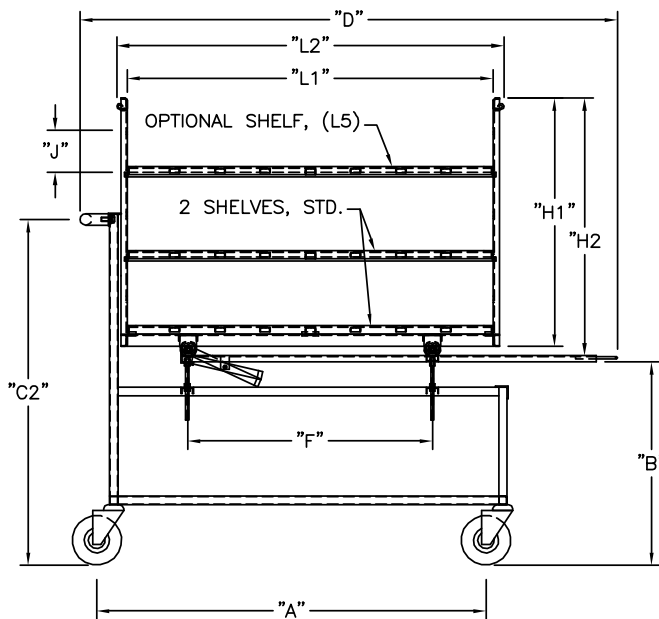

SIDE VIEW

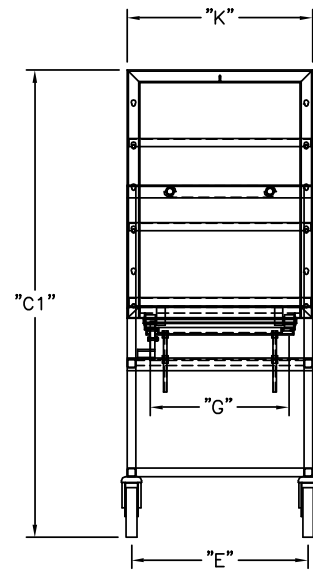

END VIEW

### The PRIMUS Difference:

- Quality and Innovation – Dedicated to sterilizers for over 25 years.
- Steam Sterilizers are Our Only Business – Proud to be the only major steam sterilizer manufacturer specializing in Steam Sterilizers
- ASME Certified Pressure Vessel Factory – Being the owner of our ASME shop ensures highest of quality and faster deliver times
- USA Designed and Manufactured
- 19 Standard Sizes, Custom Sizes Available
- Steam Sterilizer for Every Need – From Basic Sterilization to Hazardous Waste, to Validatable Pharmaceutical and Bio-Critical Applications
- Engineered the Service Out of Sterilizers – “Making it one of the easiest in the industry to service” per our Authorized Service Agents and Customers
- Simplicity of Design – less parts to fail
- Non-Proprietary Components – Lowers the cost of ownership, minimizes down time and provides a more efficient meantime repair
- 316L Stainless Steel Fully Jacketed Vessel (no laminates) – reduces heat-up time and loss of temperature, providing greater uniformity of chamber temperature
- Rectangular Chamber - eliminating wasted space and high utility cost
- Sliding Doors: Inherently safe doors – seal integrity. Not a burn hazard
- PRIMUS Controls with “Evergreen Migration” meaning the hardware and software is continually supported lowering total costs of ownership – All controls offer multiple options on 4 different control platforms. Through constant improvements and development PRIMUS Controls remain a leader in the industry. Simple to operate, reliable and versatile.
- Vacuum, Gravity, Liquid and Test Cycles - Standard on all Sterilizers
- Pri-Mirror® Chamber Finish – Most sanitary in the industry. Providing a mirror finish of <10 Micro Inches Ra, the result is a non-porous surface easy to clean and hostile to microorganism
- Independent Dealers, Sales Representatives and Authorized Service Agents Worldwide – offering the most coverage and flexibility
- Customer Service - Important part of PRIMUS offered through our Authorized Service Agents or directly from PRIMUS’ Service Department
- Turn Key Operation – from planning to installation to start-up and training
- FDA, ISO 9001:2000, ISO13485-2003; UL Listed, ASME Section VIII Division I, Health Canada License

PRIMUS sterilizers represent state-of-the-art technology, built to the highest standards thanks to employees who have a strong work ethic and dedication to craftsmanship. Quality products and personal service is first and foremost with PRIMUS.

PRIMUS has earned a reputation for offering  
the premier sterilizer on the market!



***“PRIMUS Sterilizer...  
...Quality by Design, Excellence by Choice”***



***26"x26"x39"  
with PSS8 Trinity Controls***

***QUALITY AND INTEGRITY FORM THE FOUNDATION OF  
PRIMUS STERILIZER COMPANY  
OUR VISION FOR CONTINUAL IMPROVEMENT IS REALIZED  
THROUGH THE ESTABLISHMENT OF QUALITY OBJECTIVES  
ACHIEVED THROUGH TEAMWORK WITH A GOAL OF  
RETURNING SIGNIFICANT VALUE TO OUR CUSTOMERS.***

*This document and data contained within is intended for the exclusive use of PRIMUS customers, including architects or designers. It shall not be reproduced in whole or in part without permission of PRIMUS Sterilizer Company, LLC. Any authorized reproduction must bear the entire page to include Headers and Footers.*



**PRIMUS** Sterilizer Company, LLC • 8719 South 135<sup>th</sup> Street Ste 300 • Omaha, NE 68138  
Phone (402) 344-4200 • Fax (402) 344-4242 • [info@primus-sterilizer.com](mailto:info@primus-sterilizer.com) • [www.primus-sterilizer.com](http://www.primus-sterilizer.com)





# PRIMUS Technical Data Worksheet

Complete the following by selecting the options or transferring the options, checked on preceding pages, required to meet your needs. Tear off and forward completed worksheet to PRIMUS Sales Department, fax 402-344-4251, or your local PRIMUS Representative. If you do not find an option or size listed to meet your requirement, please contact our Sales Department for additional information and assistance with a custom design to meet your specifications.

PRIMUS MODEL NUMBER		QUANTITY	
PROJECT NAME			
PROJECT ADDRESS			
COMPANY NAME		PHONE	
CONTACT NAME		FAX	
CONTACT EMAIL			
SPECIFICATION SECTION		ITEM NO.	
SHOWN ON DRAWING NO.		ROOM NO.	
PRIMUS QUOTE NO.			

GENERAL CONFIGURATIONS	
DA	Single Door
DB	Double Door
DE	Door(s) Manually Operated (Std)
CD	Cabinet, 2 sides
CCL	Cabinet, 1 Side Left
CCR	Cabinet, 1 Side Right
CA	Recessed, 1 Wall
CB	Recessed, 2 Wall
NPN	Left Side Service (Std)
C30	Right Side Service Access & Control
C31	Control Panel Opposite Side of Service
CF	Rear Panel
CG	Hinged Access Panel thru Fascia
STEAM SOURCE	
EB1	Boiler, 208/3ph
EB2	Boiler, 240/3ph
EB3	Boiler, 480/3ph
EBC1	Clean Steam, 208/3ph
EBC2	Clean Steam, 240/3ph
EB3	Clean Steam, 480/3ph
SCS1	Pure Steam Double Tube, Sanitary
SCS2	Clean Steam Single Tube
SCS3	Clean Steam Single Tube, Sanitary
EBO	Automatic boiler blow-down
BLWC	Low Water Cutoff, Manual Reset
PHARMACEUTICAL OPTIONS	
P9	Clean Steam to Chamber, Threaded Piping
P9.1	Clean Steam to Jacket, Threaded Piping
P11	Air-Over Cooling
C24	Control Cycle on Load Temperature
CONTROLS & RELATED OPTIONS	
C7	Pri-Matic Control System, PSS7 (ControlLogix)
C8	Trinity Control System, PSS8
C2	Pri-Matic F <sub>0</sub> control F <sub>0</sub> accumulated, 4 points
C9	Pri-Matic Control System, PSS9 (MicroLogix)
C23	SCADA Data File

CONTROLS & RELATED OPTIONS (con't)	
C11	Serial Data Output
C13	Sterilize Filter Cycle
C32	Authorized Operator Access
C10	Remote Mount Control Panel
R7	Thermal Printer, Take-up Reel (Std)
R1	Impact Printer, Flush Mount, 24 Col
BIO-CONTAINMENT OPTIONS	
V6	One BioSeal Flange
V7	Air Differential/Vermin Seal, Aluminum
P10	Compressed Air to Gasket
C1	Conax Adapter
C23	Remote Alarm Signal
V11	Fully Welded BioSeal Box
GENERAL OPTIONS	
V3.1	Validation Port, 1.0" diameter
V8	Seismic Restraint
P4	Electric Vacuum Pump (Std)
P25	Drain Line Strainer/Valve
DF	Automatically Operated Door
EAC	Air Compressor
UTILITY - RELATED OPTIONS	
P6	Quench Water to Drain, on Demand (Std)
E1A	Stepping Transformer from 220V to 110V
E1B	Stepping Transformer from 480V to 110V
E1C	Stepping Transformer from 480/240-240V 120V, 1 ph, 0.5KVA
E2	UPS maintains sterilizer operation for 30 minutes during power outage
E3	GFI Receptacle
P24	PRI-Saver™ Water Conservation System
P30	PRI-Pure™ Reverse Osmosis System

Std = Standard Component  
 SS = Stainless Steel  
 CIP = Clean-in-Place  
 N/A = Not Available

(Continue on the next page)

## Specification Data Worksheet (con't)

LOADING EQUIPMENT	
L2.1	Extendable Bottom Shelf, Mesh
L2	Extendable Bottom Shelf (Std)
L3	Additional Chamber Shelves
L4	Loading Cart
L5	Additional Cart Shelves
L6	Transfer Carriage
L10	Heavy Duty Loading Cart
OTHER CONTROL OPTIONS	
C3	Blind Flange Assembly, Sanitary Fitting
C4	Jacket Pressure Display, Analog
C1.2	16/24 Thermocouples Conax Adapter
C7.1	Second PanelView 1000
C14	WFI Interface
C15	Pri-Matic in NEMA 12 <sup>1</sup> enclosure (Dustproof)
C15.1	Stainless Steel Enclosure for Pri-Matic Control Panel
C16	Pri-Matic mounted in NEMA 4 <sup>2</sup> Enclosure (Waterproof)
C16.1	Pri-Matic mounted in NEMA 4X <sup>3</sup> SS Enclosure
C17	Remote Sterilizer "OFF" Signal
C18	Remote Sterilizer "In-Cycle" Signal
C23	Remote Alarm Signal
C26	PanelView 550, Service Area
C29	Additional Operational Manuals ( 2 CD provided) <b>Qty</b> _____
C30	Right Side Service Access & Controls
BC31	Control Panel Opposite Side of Service
R3	Strip-Chart Recorder
4.1	Thermal Printer, Flush Mount 24 Col.
R5	Circular Chart Recorder
R6	Impact Printer, 24 Column

OTHER PIPING OPTIONS	
P2	Heated Air-In, Heat Exchanger SS
P5	Safety Valve Over Rupture Disk
P15	Sanitary Piping (Std)
P16	Air to Jacket Cooling
P18	Passivate Chamber
P19	Passivate Chamber and Piping
P20	Steam Quality Sampler
VESSEL OPTIONS	
V1	Stainless Steel Frame
V2	Jacket Type, 316 L SS
V3	Jacket Insulation Cover, SS
V6.1	Additional BioSeal Flange (N/A 26x26x39)
V8	Seismic Restraints
V10	BioSeal Panels, Stainless
GMP DOCUMENTATION OPTIONS	
D1	GMP Validation Documentation
D4	IQ/OQ Protocol, PSS8 Trinity
D3	IQ/OQ Protocol, Pri-Matic

Std = Standard Component  
 SS = Stainless Steel  
 N/A = Not Available  
 1 = NEMA 12 (IP55), Dustproof, Painted Steel Enclosure  
 2 = NEMA 4, Waterproof, Stainless Steel Enclosure  
 3 = NEMA 4X (IP66), Waterproof, Stainless Steel Enclosure  
 GMP Validation Documentaion includes the following:  
 In-Process Inspection Traveler  
 Weld Map  
 Weld Procedure Specifications (WPS)  
 Welder or Welder Operator Qualification Test (WPQ)  
 Material Heat Code List (Code Components)  
 Material Certifications and Mill Test Reports  
 Chamber Mapping Test Runs and graphs  
 Heat Numbers of all SS Components  
 Manufacturer's Specification Datasheets and/or Instruction Manual for all Major Components  
 Major Components on MPL Tagged

**YOUR LOCAL PRIMUS REPRESENTATIVE:**

**FOR ADDITIONAL ASSISTANCE**

To discuss your sterilization design needs please contact PRIMUS.

*Manufacturer reserves the right to modify materials or specification without notice.*



**PRIMUS** Sterilizer Company, LLC • 8719 South 135<sup>th</sup> Street Ste 300 • Omaha, NE 68138  
 Phone (402) 344-4200 • Fax (402) 344-4242 • [info@primus-sterilizer.com](mailto:info@primus-sterilizer.com) • [www.primus-sterilizer.com](http://www.primus-sterilizer.com)

